

Celtic Rollerball / Fountain Pen Kit

Kit Features:

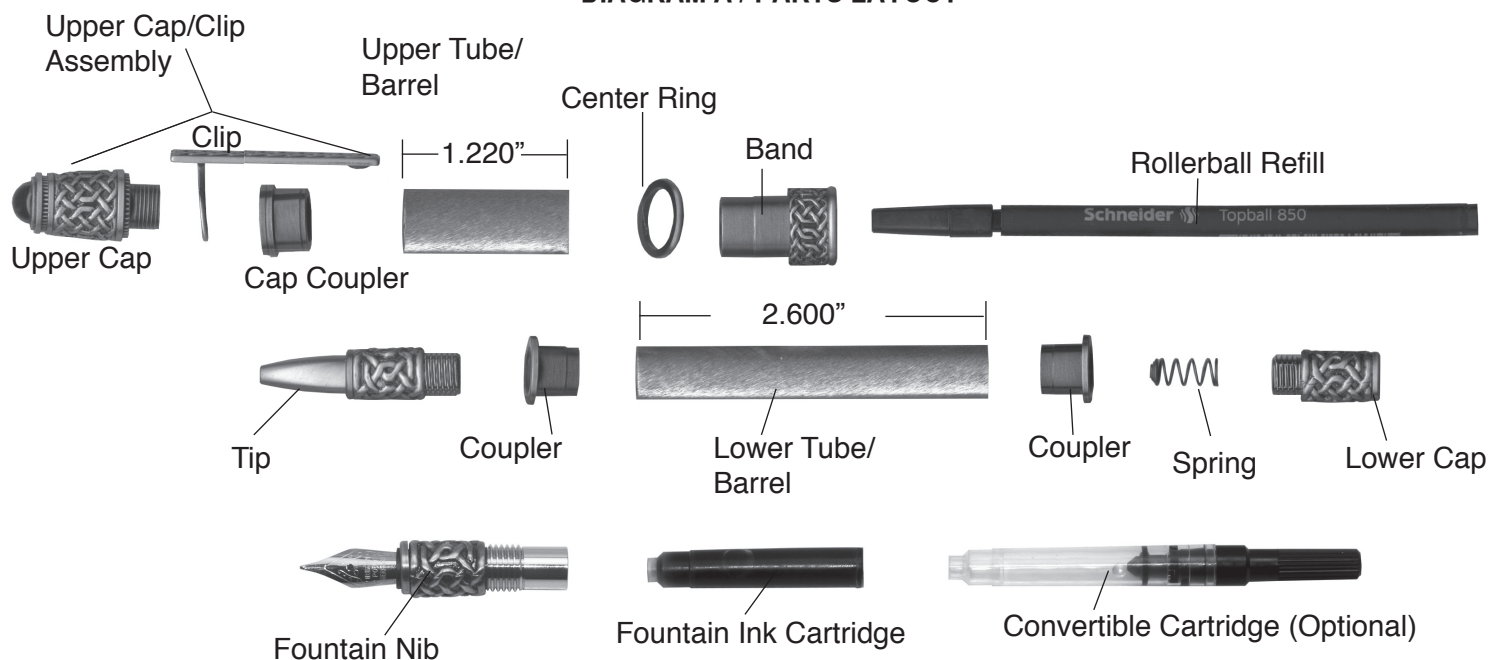
- Easy to turn with straight tubes
- Minimum parts - easy to assemble
- Available in multiple finishes
- Uses Schneider #850 refill (Rollerball)
- Fountain Pen includes ink cartridge
- Magnetic Cap
- Iridium Tipped Fountain Nib
- Overall Length: 5-13/16"

Required Accessories:

- 7mm Pen Mandrel
- Drill Bit(s): #PK105MM (10.5mm) and #PKPLI-DB (12.5mm)
- Bushing set(3 pc): #PKCPENRBU
- Barrel Trimming set: #PKMAJJRBTSS
- Live Tailstock Center
- 2 Part Epoxy Glue or Insta Cure (Cyanoacrylate) Glue
- Pen Blank: Minimum Size - 3/4" x 4-1/4" Long

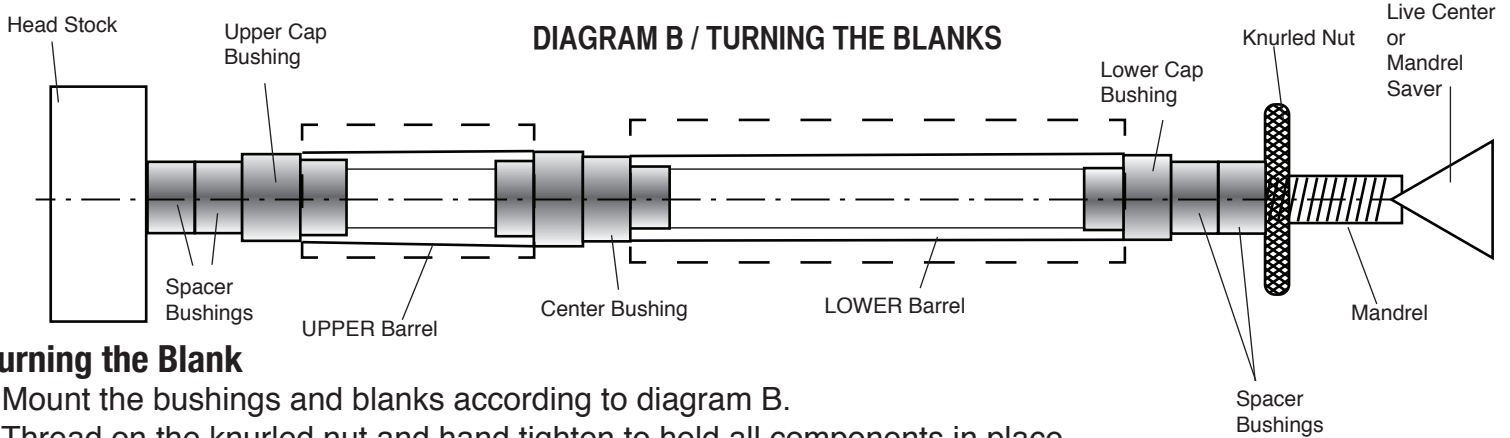


DIAGRAM A / PARTS LAYOUT



Preparing the Blank:

- Cut 2 blanks to the length of the tubes and add 1/16" for squaring off.
- Drill 12.5mm (upper) and 10.5mm (lower) holes lengthwise through the blanks.
- Spread glue over the tubes, insert the blank with a twisting motion to spread the glue evenly inside.
- Center the tubes lengthwise inside the blanks.
- When the glue is dry, square the ends of the blanks. Use a 7mm barrel trimmer with the trimming sleeves, or a universal pen blank squaring jig with a power disc sander. Take the excess material down flush with the ends of the brass tube. (do not trim beyond the length of the tube since this may interfere with operation of the pen and assembly).



Turning the Blank

- Mount the bushings and blanks according to diagram B.
- Thread on the knurled nut and hand tighten to hold all components in place.
- Slide the tailstock up snugly against the mandrel shaft inserting the live center point into the mandrel dimple, lock in place.
- Hand tighten the quill adjustment to firm up the mandrel. (DO NOT overtighten, it could damage the mandrel.
- Using sharp tools, turn the blank down close to the bushing diameter. Turn the barrel (straight or to a pro file of your choice)
- Sand the blank down to be flush with the bushings gradually increasing the sandpaper grits.
- Finish the barrel with your choice of polish. Allow sufficient time for the polish to cure. Refer to polish instructions.

Assembly

- Layout parts according to diagram A
- Press the upper cap assembly, recessed end into the narrow diameter of the upper barrel.
- Slide the center ring over the recess of the band. Press the barrel assembly into the opposite end of the upper barrel.

NOTE: When pressing, be sure the cap stone is at the soft side of the pen press to avoid damage.

- Press couplers into each end of the lower barrel.
- Thread the lower cap onto either end of the lower barrel.

For Rollerball:

- Drop the spring, wide end in first into the opening at the opposite end of the barrel.
- Remove the protector cover of the refill and drop, back (end) side in first over the spring, at the opening.
- Affix and screw the tip into the coupler, over the refill tip.
- Engage cap when not in use to avoid the ink from drying up.

For Fountain:

- Affix either the ink cartridge or convertible into the back of the fountain nib. Push in to connect.
- Screw this assembly into the opening at the barrel.
- Shake the pen to advance the ink.

Diagram C / Bushings #PKCPENRBU

