

OLYMPIAN ELITE PEN KIT

KIT FEATURES

- Heavy plating with epoxy coating.
- Elegant features on a lightweight pen.
- Premium pen roller ball refill - PK10-RPR
- Overall length 5-5/8"

REQUIRED ACCESSORIES:

- 7mm pen mandrel
- 3-pc. bushing set - #PKOLBU
- 31/64" drill bit - #PK3164
- 33/64" drill bit - #PK3364
- 2-pc set barrel trimmer sleeve #PKOLBTS
- Universal barrel trimmer kit #PKTRIMKIT
- 2-part epoxy glue or insta-cure glue (cyano-acrylate).

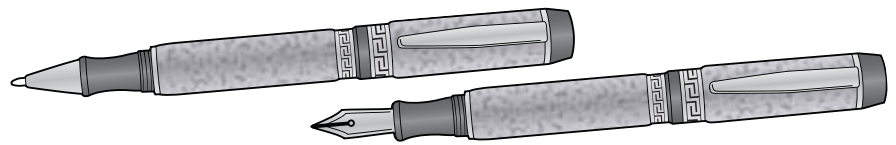
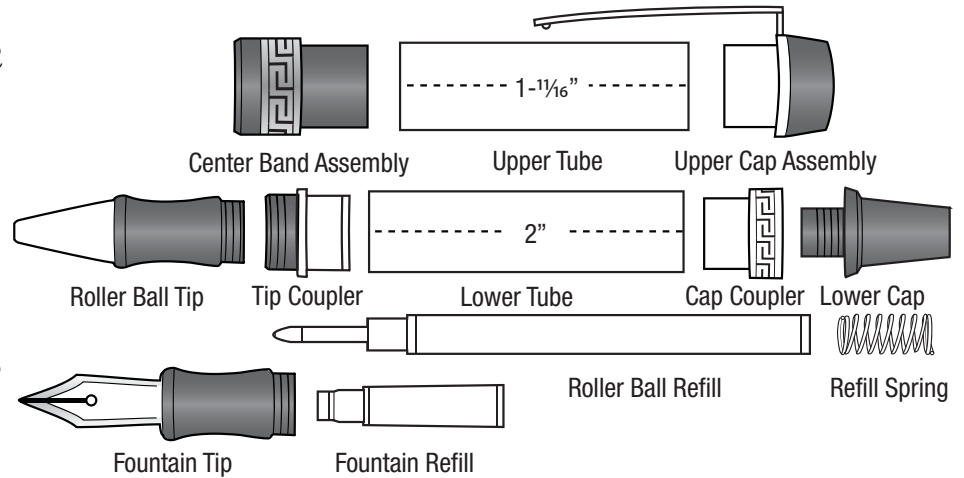

DIAGRAM A • Parts List



PREPARING THE BLANKS:

- Prepare a master blank of at least 3/4" square. Cut two sections to the length of each tube. (Add 1/16" for trimming) Mark the center of each blank.
 - Upper Blank - (shorter tube) - drill a 33/64" hole through the blank
 - Lower Blank - (longer tube) - drill a 31/64" hole through.
- NOTE:** sand the tubes using 220-grit abrasive for better adhesion.
- Glue each tube in the proper blank. Spread the glue over each tube. Insert the tube into the blank with a twisting motion to spread the glue evenly inside. Center each tube lengthwise inside the blank.
 - When glue dries; square the ends of each blank. Using a 7mm barrel trimmer with sleeves(#PKOLBTS). Mount the proper sleeve over the 7mm shank (smaller diameter for the longer tube, large diameter for the short tube). Trim the blank down flush with the brass tube.

TURNING THE BLANKS:

- Mount 7mm spacer bushings on the mandrel followed by the tip bushing (smallest) wide end first. Slide the lower blank (longer) on next. Follow with the center bushing, narrow diameter first. Next, add the upper blank and follow with the cap bushing, narrow end first. Mount spacer bushings to fill the space to the threads on the mandrel.
- Screw on the lock nut hand tight. Bring the tailstock in snug to the mandrel. Lock in place. Do not over-tighten the lock nut; it may damage the mandrel.
- Turn the blanks down close to the bushings. Follow with abrasives until the tube diameters are flush with the bushings. Finish with your choice of polish.

DIAGRAM B • Turning the blanks

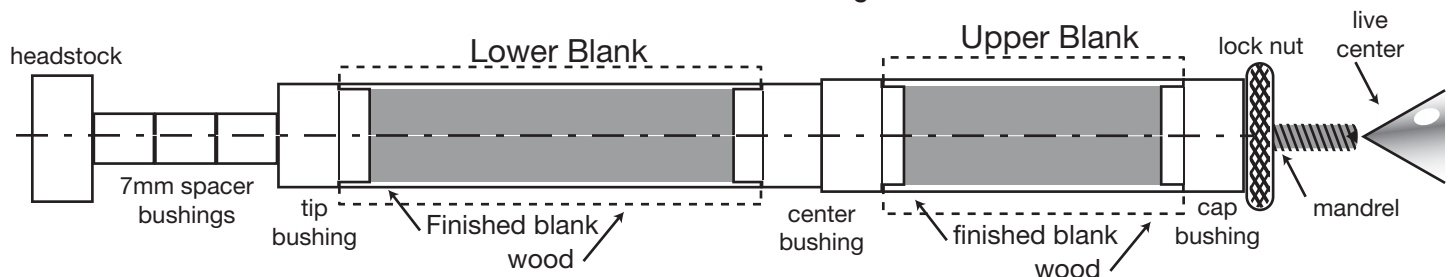
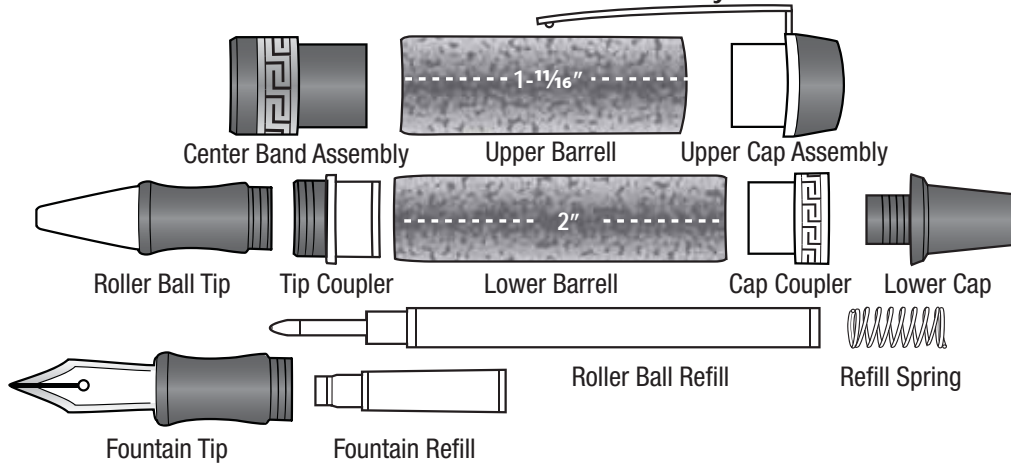

DIAGRAM C • Pen Assembly



ASSEMBLY:

NOTE: Line up the components according to Diagram 'C'.

To avoid damage to components when assembling pen use vise with covered jaws or PSI #PENPRESS3.

- Press the center band assembly into the upper barrel (shorter tube).
- Press the upper cap/clip assembly into the opposite end of the upper barrel.
- Press the tip coupler, recessed end in first into the lower barrel.
- Press the cap coupler into the opposite end of the barrel.
- Thread the lower cap into the cap coupler.

TIPS

- Consider matching the wood grain when assembling the pen.
- When engaging the ends to close the pen, notice that the threads have three starting points so you can quickly close the pen in either of three positions.

ROLLER BALL

- Drop the refill spring, wide diameter first into the opening at the coupler.
- Remove the protective sleeve off the refill and insert wide end in first into the opening at the coupler.
- Thread the roller tip over the refill into the threaded coupler.

FOUNTAIN PEN

- Affix the ink reservoir, narrow end first into the back of the pen nib. Push in to break the seal (or use PSI refillable reservoirs #PKPUMP5), then press the tip lightly to advance the ink forward.
- Thread the fountain nib assembly over the threaded coupler.

DIAGRAM D • PKOLBU

